

MANUAL

Enbar U1 and U2

LVM area treatment



Version: 2023-05

FOREWORD

This manual is intended for the users and technicians of the Enbar LVM, types U1 and U2.

Please read the entire manual carefully and keep it in a safe place for future reference. If (any part of) the manual is damaged or mislaid at any time during the life-cycle of the system, a new copy can be obtained free of charge from the manufacturer.

The manual consists of various chapters divided into sections, each section having multiple subsections or paragraphs. If a term is followed by a figure between brackets, this refers to the numbering applied in illustrations 1 and/or 2.

The manual covers the following topics:

- General information
- Safety specifications, with explanatory notes on the safety symbols applied.
- Description of the Enbar.
- Installation and assembly.
- Instructions for use.
- Maintenance.
- Repairs and malfunctions.

Several annexes can be found at the back of the manual, including an exploded view of the filter and nozzle.

The table of contents lists all topics and their relevant sections in the manual.

CONTENT

Foreword	2
Content.....	3
1 Identification.....	4
1.1 General	4
1.1.1 Description of the installation	4
1.1.2 Technical specifications	4
1.2 Operators	4
1.3 Use.....	5
1.4 Media	5
1.5 Connections.....	5
1.6 Application environment	6
1.7 Warranty conditions	6
1.8 Relevant directives	6
2 Description	7
2.1 Principles of operation	7
2.2 Components	8
3 Safety instructions.....	9
3.1 Information regarding the crop protection products.....	9
3.2 General safety instructions	9
3.3 Summary of all safety labels used.....	10
3.3.1 General	11
3.3.2 Testing the installation	11
3.3.3 Preparing the crop protection product.....	12
3.3.4 Start-up	12
3.3.5 Operation and use of the installation	13
3.3.6 After use of the installation.....	13
3.3.7 Maintaining and cleaning the installation	13
3.4 Summary of remaining risks	14
4 Operation	14
4.1 Controls.....	14
4.2 Installing.....	15
4.2.1 Installation of the Enbar type U1	15
4.2.2 Installation of the Enbar type U2.....	16
4.3 Example Enbar suspension	17
4.4 Pre-ventilation	20
4.5 Filling and start up	20
4.6 Testing (U1 only)	21
4.7 Disconnecting	21
4.8 Starting after a power interruption	22
5 Maintenance.....	22
5.1 Cleaning after use.....	22
5.2 Yearly maintenance	23
5.2.1 Safety regulations	23
5.2.2 Unit.....	23
6 Troubleshooting	25
7 CE Declaration of conformity	26
8 UKCA declaration of conformity.....	27
Annexes	28
Construction of the nozzle	29
Construction of the fluidfilter	30
Electrical wiring diagram U1	31
Replacement of fuse in U1 type.....	32
Time cycle diagram.....	33

1 IDENTIFICATION

This section describes the general specifications, components, designated use and prescribed operating conditions.

1.1 General

1.1.1 Description of the installation

The Enbar LVM (or Enbar in short) is a machine used for the automatic sprayed dispersal of crop spraying agents. The Enbar atomizes the agents in stream of air. The atomized agents remain suspended in the air for some time, thus ensuring the thorough dispersal of the agents and optimal penetration of the respective crops.

The machine largely consists of a ventilator fan, an atomizer (nozzle), a control unit and a fluid tank.

The U1 type is connected to a compressed air and water network and has the necessary valves and relays fitted beneath the ventilator fan. The atomization time and/or starting times can be selected for each individual greenhouse section via the separate control unit (for each Enbar). The U1 type is suitable for use in greenhouses that are divided into several different smaller crop sections.

The U2 type is connected to a centrally controlled compressed air and water network and relay. This type therefore shares the valves and relays via a central control unit. The U2 type is suited for use in greenhouses with large crop sections where several Enbars are used in each section.

The Enbar is only intended to be used for the atomization (misting) of crop spraying agents in enclosed crop cultivation spaces.

1.1.2 Technical specifications

	U1	U2
Dimensions [L x W x H] [mm]	600 x 320 x 755	600 x 320 x 755
Weight	17 kg	15 kg
Voltage	230 V	
Volume fluid reservoir	5L (optional 10 L)	
Volume Rinse tank (optional)	1L	
Atomizing solution output	2,5 L/hour per nozzle	
Air output	90 L/min at 6 bar	
Fan		
Voltage	230 V	
Power	160 W	
Nom. Current	0,71 A	
Condensor	5 μ F	
RPM	2650 rpm	
Agitator mixer		
Voltage	230 V	
Power	3,5 W	
RPM	60 rpm	
Control unit		
Voltage	230 V	
Control signal	24 VAC	

1.2 Operators

It is imperative that all operators using the Enbar read this user guide and inform themselves of the applicable safety precautions before putting the machine into operation. All operators must be designated as authorized operators by the company.

An operator is not necessarily authorized to mix the atomizing agent or modify the settings of and/or execute maintenance and repair work on the machine, unless this person is at least 18 years of age. Apart from this, operators must be certified to mix the atomizing solution through a valid Class III Spraying Certificate.

Operators must ensure that children or persons under the age of 18 and persons not wearing adequate protective clothing in such cases when this is required stay out of the direct vicinity of the Enbar. Pregnant women should neither operate nor remain in the direct vicinity of the Enbar.

1.3 Use

The installation may only be used for spraying suitable crop spraying agents.

Unintended use means the following:

- It is not permitted to use the Enbar for any other agents than those intended for crop spraying.
- It is not permitted to use the Enbar and its fluid tank for the storage of crop spraying agents. Never prepare more crop spraying agent than is absolutely necessary. Prepare the crop spraying agent for no more than 1 spraying cycle.
- If necessary, the fluid tank containing the crop spraying agent must be completely emptied once the Enbar has completed its misting and ventilation cycle. Collect the chemical agent and store in an appropriate and safe place.
- The Enbar is not suitable for use as a ladder, step or for any other purpose than for crop misting.

1.4 Media

Placing an image/comment in relation to the Enbar should always be discussed in advance with the producer/supplier. If this is not observed, any consequential damage can be recovered from this person/company.

1.5 Connections

Connect the Enbar to an earthed electrical wall socket that is adequately safeguarded with an automatic 16A fuse in combination with a 30 mA earth leakage protection unit. The connecting voltage of the fixed Enbar (types U1 and U2) is 230V.

A 24 VAC connection is required for the control of the Enbar U1.

Use a quick-release safety coupling that is well within the field of view of the Enbar.

1.6 Application environment

Due to the risks involved in the use of the crop spraying agent, eating, drinking and smoking in the vicinity of the installation should not be permitted.

The space or environment in which the Enbar is used may not be accessed when the Enbar is in operation.

Always maintain ample space around the installation in order to avoid any hazards that may occur.

The ambient temperature for the operation of the Enbar must be at least 5°C and no more than 40°C. The relative air humidity must be at least 45% and no more than 85%.

The Enbar is intended for use in enclosed crop cultivation spaces.

1.7 Warranty conditions

The warranty applies for a period of 6 months commencing from the first date of use. The maximum validity of the warranty is 2 years following the date of manufacture.

Any warranty claims made must be submitted to the manufacturer together with the respective parts for the purpose of evaluation.

- The warranty is no longer valid in the event of:
- Incompetent use or assembly.
- Repeated failure to follow recommendations and instructions provided by the manufacturer and/or supplier.
- Repair, maintenance or use by unauthorized persons.
- Use of unsuitable electrical or other connections.
- Use of the machine in an unsuitable environment.
- Intentional damage or changes to the machine.

The warranty conditions comply with the Recommendations and requirements of the metal and engineering association.

1.8 Relevant directives

The Enbar meets the standards stated on the declaration.

The Enbar is a Class I device according to the 2006/95/EC Low Voltage Directive (LVD).

The CE and UKCA designation of the U1 can be found on the side of the control unit.

The CE and UKCA designation of the U2 can be found on the mounting plate on the underside of the chassis beam.

2 DESCRIPTION

This section explains the operation of the Enbar and also provides schematic diagrams showing the location of the various parts.

2.1 Principles of operation

The Enbar LVM (Low-Volume Mist) is a fluid misting device that enables the controlled and thorough distribution of crop spraying agents in enclosed crop cultivation spaces, thus ensuring the optimal penetration of the respective crops.

The installation atomizes a crop spraying fluid through an airflow which disperses the atomized crop spraying agent throughout the crop cultivation space.

The general operating principle is as follows (designated numbers refer to the parts described in paragraph 2.2).

The crop spraying agent is first added to the fluid tank (6). The starting signal initiates the operation of the ventilator fan (9) and switches on the mixing paddle (5) at the same time. The mixing paddle is intended to maintain a good crop spraying solution and to prevent coagulation or precipitation of the mixture. The ventilator fan then commences with the pre-ventilation cycle so as to initiate an airflow in the greenhouse. The duration of the ventilation cycle can be pre-programmed.

A nozzle (1) is located just in front of the air outlet of the ventilator fan. This nozzle has both an air and a water connection. Once the actual misting cycle begins, the compressed air is forced through the nozzle, thus resulting in a partial vacuum due to the venturi effect in the nozzle. This partial vacuum draws the crop spraying agent through the filter (3) and flow limiter (2) and atomizes the crop spraying agent at the tip of the nozzle. Because the nozzle is located within the airflow path of the ventilator fan, the crop spraying agent is forced through the airflow and is dispersed in the air throughout the entire crop enclosure.

The Enbar will continue to mist for the duration of the pre-programmed misting cycle and then automatically commence with the rinsing cycle. This enables the atomization of clean water from the rinsing tank (8) or from the external water supply (10). This cleans the system. Rinsing after use takes about 3 minutes. After rinsing, the machine must be ventilated for a period of approx. 7 minutes in order to properly disperse any remaining agent residue and moisture.

2.2 Components

The figure below indicates and designates all the primary components.

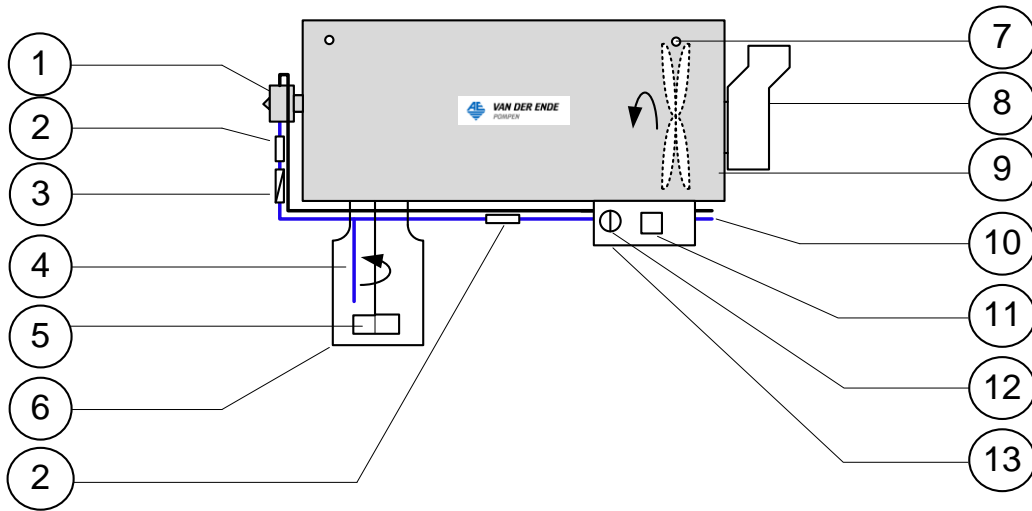

Figure 1 Enbar U1

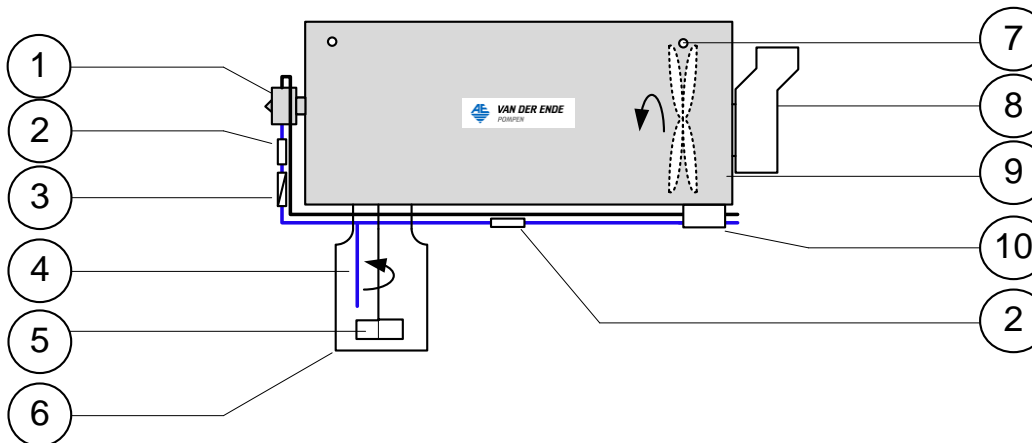

Figure 2 Enbar U2

1.	Nozzle
2.	Flow limiter (Woodpecker), 2x
3.	Filter
4.	Suction tube
5.	Agitator (mixing paddle)
6.	Fluid tank
7.	Mounting points
8.	Rinsing tank (optional)
9.	Ventilator fan
10.	Connection for water and compressed air
11.	Plug connection for control current
12.	Key switch for testing
13.	Control unit for remote control

Table 2 Components Enbar U1 and U2

3 SAFETY INSTRUCTIONS

This chapter provides information on the safe use of the Enbar. Read this section carefully and inform all persons working in the close vicinity of the Enbar about any safety risks and safety regulations.

3.1 Information regarding the crop protection products

The Enbar is used in combination with crop spraying agents. These crop spraying agents (pesticides) pose a serious safety and health risk and are often poisonous, may cause irritation and/or are detrimental to the environment.

Although the Enbar uses diluted crop spraying agents it is of primary importance that all the necessary safety precautions are taken.

- Always read the safety labels and instructions carefully before using the spraying agent!
- Ask the supplier for advice on how to use the crop spraying agent!

Always wear protective gloves and a full face mask when handling crop spraying agents. Persons responsible for preparing crop spraying agents must be certified and be in the possession of a Class III crop spraying license. Read the safety labels or contact the supplier regarding the full safety precautions relating to the use of the crop spraying agent.



Always bear in mind that the manufacturer of the Enbar is in no way responsible for the storage of the crop spraying agents used in combination with the Enbar. The user should therefore take all necessary precautions to ensure the safe handling and storage of these crop spraying agents. The storage of these crop spraying agents is not the responsibility of the manufacturer.

3.2 General safety instructions

Regulations regarding the use and preparation of the crop spraying agents:

- This installation may only be used for misting suitable crop spraying agents.
- Directly after receipt, check that the installation is complete and undamaged. Any deviations or defects should be reported to the supplier/manufacturer immediately.
- Read all the directions for use carefully before operating the installation.
- Persons responsible for preparing crop spraying agents must be certified and be in the possession of a Class III crop spraying licence.
- For the correct mixing ratios of crop spraying agents, please refer to the instructions provided by the supplier.

3.3 Summary of all safety labels used

Various different safety labels are applied to the Enbar and in this manual. These safety labels are explained below.







Symbol	Explanation
	<p>This symbol is used when there is a health risk due to the use of poisonous or hazardous chemicals.</p> <p>This symbol indicates that the use of personal protection equipment (PPE) such as protective gloves and a face mask is mandatory.</p>
	<p>This symbol is used when there is a risk of electrocution. When this symbol is used, always follow the safety instructions very carefully.</p>
	<p>Face mask</p> <p>Always wear a full face mask in order to prevent the inhalation of hazardous substances via the mouth or nose.</p>
	<p>Gloves</p> <p>When using a product that has this icon, always wear gloves to prevent the exposure to and/or spreading of hazardous substances via the hands</p>
	<p>Overalls</p> <p>When this symbol is used, always wear a protective overall or other protective clothing in order to prevent the intake and/or dispersal of hazardous chemicals via the skin.</p>
	<p>User Manual</p> <p>When this symbol is used, always read the instruction manual before use.</p>
	<p>Rinsing hands</p> <p>Always wash and rinse your hands thoroughly after use.</p>

Table 3 Used safety labels with description

3.3.1 General





	<ul style="list-style-type: none"> • Always avoid physical contact with the chemical agent. • Keep children under the age of 18 years and pregnant women well away from the equipment. • Always clean up any spills immediately. • Never prepare more spraying agent than is absolutely necessary. • When using the Enbar, avoid physical contact with the eyes, mouth and nose at all times.
	<ul style="list-style-type: none"> • Always ensure that the grille guards and protective covers are properly mounted.
	<ul style="list-style-type: none"> • Replace gloves, protective clothing and the filters of the face mask regularly.
	<ul style="list-style-type: none"> • Ensure that all persons using the Enbar or working in the close vicinity of the Enbar are aware of the safety instructions and precautions.
	<ul style="list-style-type: none"> • Always wash and rinse off lower arms and hands thoroughly after handling and/or using crop spraying agents

Table 4 General safety regulations

3.3.2 Testing the installation



	<ul style="list-style-type: none"> • Always ensure that the fluid tank is filled with clean water without chemicals when testing.
	<ul style="list-style-type: none"> • Connect the Enbar to an electrical wall socket;
	<ul style="list-style-type: none"> • Ensure that the fluid tank is mounted properly. • Remove the key from the key switch after use. • Always use a quick-release safety coupling for the compressed air connection!

Table 5 Safety regulations for testing the installation

3.3.3 Preparing the crop protection product





	<ul style="list-style-type: none"> • Always wear protective clothing, tightly fitting gloves and a face mask.
	<ul style="list-style-type: none"> • Always close the packaging carefully after weighing/measuring the crop spraying agent. • Always store the packaging safely and securely after weighing/measuring. • The fluid container must be mounted immediately after preparing the spraying agent.
	<ul style="list-style-type: none"> • Do not eat, smoke and drink or pick your nose when preparing the spraying agent. • Always read the safety label on the packaging: this includes the instructions for use, legally required instructions for use, safety warnings and the recommendations for safe use. • Always follow the safety instructions on the labels.
	<ul style="list-style-type: none"> • Always wash lower arms and hands thoroughly with soap and water after handling and/or using crop spraying agents

Table 6 Safety regulations for preparing the chemicals

3.3.4 Start-up





	<ul style="list-style-type: none"> • Check that there are no persons present in the enclosed crop spraying space. • Always take precautions to ensure that no persons can access the space to be sprayed when the installation is in operation. • Before use, inform personnel and all other persons present that the Enbar is about to be put into operation. • Attach warning signs to the entrance doors of the space to be sprayed.
	<ul style="list-style-type: none"> • Ensure that the air ventilation windows and doors to the exterior are securely closed in order to prevent the escape of the atomized spraying agent from the enclosed crop spraying space.
	<ul style="list-style-type: none"> • Connect the Enbar to an electrical wall socket; • Follow all connection requirements carefully.
	<ul style="list-style-type: none"> • Ensure that the fluid tank is mounted properly. • Ensure that the ventilator fans blow air in the direction of the spray path (parallel to the spray path).

Table 7 Safety regulations for starting up the installation

3.3.5 Operation and use of the installation



	<ul style="list-style-type: none"> • Always ensure that no persons can access the space to be sprayed when the installation is in operation.
	<ul style="list-style-type: none"> • Ensure that the air ventilation windows and doors to the exterior are securely closed in order to prevent the escape of the atomized spraying agent from the crop spraying space.

Table 8 Safety regulations while operating the installation

3.3.6 After use of the installation



	<ul style="list-style-type: none"> • After spraying, ventilate the crop space for several hours. • Only enter the crop space after the installation has completed the post-ventilation cycle and the crop space has been well ventilated. • Check whether the fluid tank is empty and ensure that it is emptied. Treat any residual fluids as (hazardous) chemical waste.
	<ul style="list-style-type: none"> • Remove the electrical power plug from the wall socket.

Table 9 Safety regulations after using the installation

3.3.7 Maintaining and cleaning the installation





	<ul style="list-style-type: none"> • Always ensure that the spraying agent is completely emptied and removed before performing work on the Enbar!
	<ul style="list-style-type: none"> • Always disconnect the compressed air connection before performing work on the Enbar!
	<ul style="list-style-type: none"> • Always remove the electrical power plug from the wall socket before cleaning or performing maintenance on the Enbar.
	<ul style="list-style-type: none"> • Always wear protective gloves and clothing.
	<ul style="list-style-type: none"> • Always wash and rinse off lower arms and hands thoroughly after handling and/or using crop spraying agents.

Table 10 Safety regulations for maintenance

3.4 Summary of remaining risks

The user of this installation must be aware of the fact that there are risks related to the use of the installation. These risks have been safeguarded as much as possible by the manufacturer but these risks may always be present if the user ignores or fails to comply with safety instructions or instructions for use. The following table provides an overview of the residual risks and other risks that may occur if the user ignores or fails to comply with the instructions.

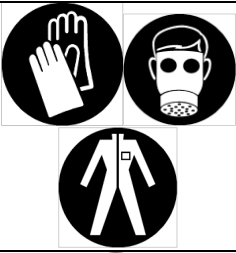
Risk sheet no.	Description of residual risks
1. and 2.	The agents that are used in combination with the application (atomization) are hazardous to the user. Because this risk is inherent to the function of the machine, it cannot be covered any further.
8.	The Enbar can fall if the installation is incorrectly mounted at all four mounting points or if the lifting device is used incorrectly.
7.	The fluid tank must be mounted correctly. If the tank is not mounted correctly this could lead to leakages and/or to the complete loss of the fluid contents.

Table 11 List of residual risks

4 OPERATION

This section contains the instructions for use. Any figures used in this section relate to the schematic diagram of the Enbar in paragraph 2.2. These instructions for use only apply if Van der Ende B.V. has supplied the Enbar together with a standard central control unit.



If Van der Ende group B.V. has not supplied the Enbar together with a standard central control unit the supplier of the control unit must provide the instructions for use. The logical control of the Enbar must be safe and effective. If Van der Ende B.V. has not supplied the Enbar together with a standard central control unit the supplier of the control unit must provide the instructions for use. The logical control of the Enbar must be safe and effective.

4.1 Controls

Only the U1 has a control mechanism, i.e. a key-operated switch for testing atomization. This switch can only be operated using the correct key. The switch on the Enbar is used to start the misting operation. This is so that the user can perform a visual test directly. The test must be performed using clean water only, i.e. without the use of chemicals!

4.2 Installing

The installation of the U1 type differs slightly from that of the U2 type. This is related to the fact that the air, water and electrical power supply is controlled via a central control unit. Both types are explained below in more detail and an explanatory situational sketch is given.

4.2.1 Installation of the Enbar type U1

- Mount the Enbar to a stable construction at the top of the greenhouse.
 - **do not** mount the Enbar directly above the crops but mount the installation so that it can be easily accessed without posing a safety risk;
- mount the Enbar in such a manner that there is a free space (free from any obstacles, crops etc.) of at least 20 meters in the direction of the air flow;
- connect the Enbar to an electrical wall socket;
 - use an earthed wall socket;
 - ensure that the electrical wall socket is equipped with a fuse of max. 16A in combination with an earth leakage protector of 30 mA;
- connect the Enbar to a compressed air connection;
 - use a quick-release safety coupling that is well within the field of view of the Enbar.
 - in order to perform maintenance etc. the Enbar must be disconnected safely and efficiently. The maintenance technician must be able to access and check these coupling means effectively at all times;
 - if the above is not possible, the shut-off valve must be secured, for example by the use of a padlock;
- connect the Enbar to a water supply line;
 - only if there is no rinsing tank;
 - use tube size of 8 mm with appropriate hose clips;
 - ensure that there is sufficient water pressure;
 - use a non-return valve between the water line and the installation;
 - always comply with locally applicable regulations regarding safety;
- connect the Enbar to a 24 VAC control circuit using the special control current connector (11);
 - the Enbar U1 can be controlled by connecting the voltage to one of the terminals on the control circuit connector plug. For example, if the voltage is connected to terminal 1 the Enbar will continue to ventilate as long as the power supply is maintained.
 - the numbering of the terminal points of the connector plug is as follows: 1 = ventilation; 2 = misting/atomization; 3 = rinsing after use; 4 = zero;
 - this alternate control procedure enables logical programming - see the time cycle diagram in the annexes for additional help;
- See also figure 3 below and the electrical wiring diagram (page 40) in the annexes.

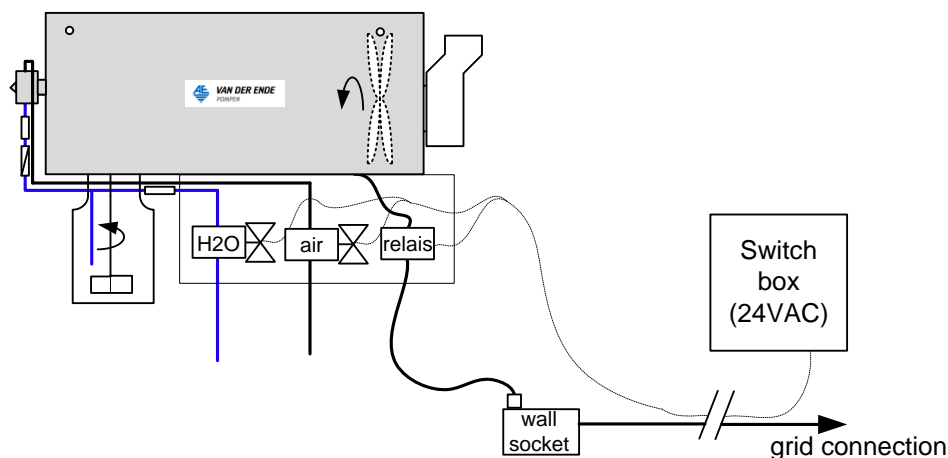

Figure 3 Installation of the Enbar, U1 type

4.2.2 Installation of the Enbar type U2

- Mount the Enbar to a stable construction at the top of the greenhouse.
 - **do not** mount the Enbar directly above the crops but mount the installation so that the installation can be easily accessed without posing a safety risk;
- mount the Enbar in such a manner that there is a free space (free from any obstacles, crops etc.) of at least 20 metres in the direction of the air flow;
- connect the Enbar to an electrical wall socket;
 - use a switched wall socket;
 - this enables the Enbar to be switched on and off;
 - use an earthed wall socket;
 - ensure that the electrical wall socket is equipped with a fuse of max. 16A in combination with a 30 mA earth leakage protector;
- connect the Enbar to a compressed air line;
 - use a quick-release safety coupling that is well within the field of view of the Enbar.
 - in order to perform maintenance etc. the Enbar must be disconnected safely and efficiently. The maintenance technician must be able to access and check these coupling means effectively at all times;
 - if the above is not possible, the shut-off valve must be secured, for example by the use of a padlock;
- connect the Enbar to a water line;
 - only if there is no rinsing tank present;
 - use an 8 mm diam. connection hose with suitable hose clips;
 - ensure that there is sufficient water pressure;
 - use a non-return valve between the water line and the installation;
 - always comply with locally applicable regulations regarding safety;
- the Enbar can be controlled by using a switched power circuit for the compressed air connection and for the water connection after applying pressure to the circuit in combination with the switching operation;
- this control enables a logical programming - see the time diagram in the annexes for additional help;
- Refer to figure 4 for a situational sketch.

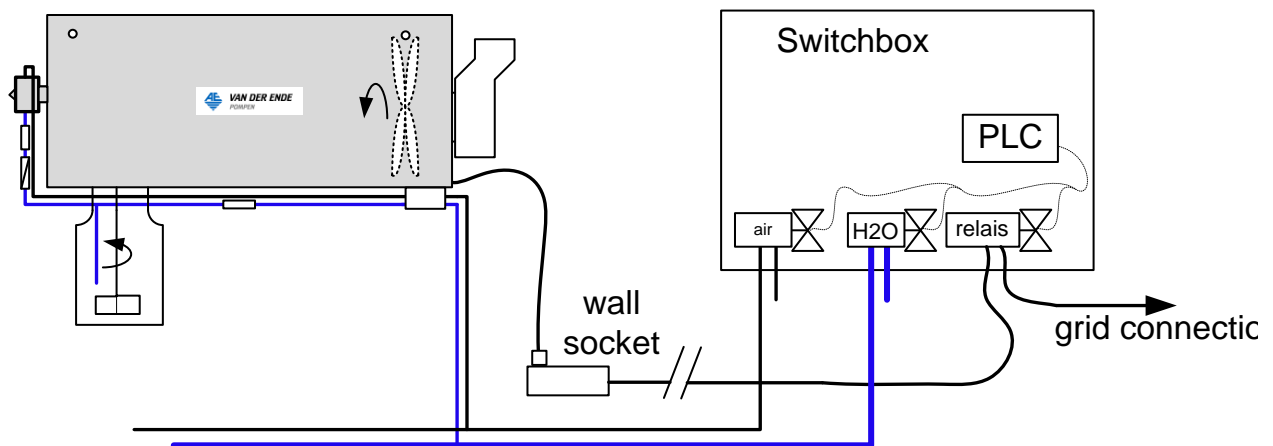

Figure 4 Installation of the Enbar, U2 type

4.3 Example Enbar suspension



Picture 1 Suspension double Enbar

The double Enbar in a permanent setup (a) is suspended by a frame(b) that is connected to a winch system. The two Enbar units are mounted to the frame by 8 fastener sets(c). These sets consist out of the following parts;

- 1x S-hook no. 40
- 1x Eye bolt m6x80
- 2x Fender washer m6
- 2x Split washer m6
- 2x Nut m6

When the units are mounted to the frame, the complete set can be mounted to the winch system. The system uses 3mm thick stainless steel wires. Figure 6 shows the correct way to mount the wire to the frame by using one wire clamp. We advise to tape the wire before cutting it (d), to minimize the chance for frayed wires.



Figure 5 Loop with 1 wire clamp

For the winch system the following parts are provided;

- 10x Wire clamp 3/16" m5
- 8x Pulley 2" with plastic Wheel and bearing
- 1x Manual winch

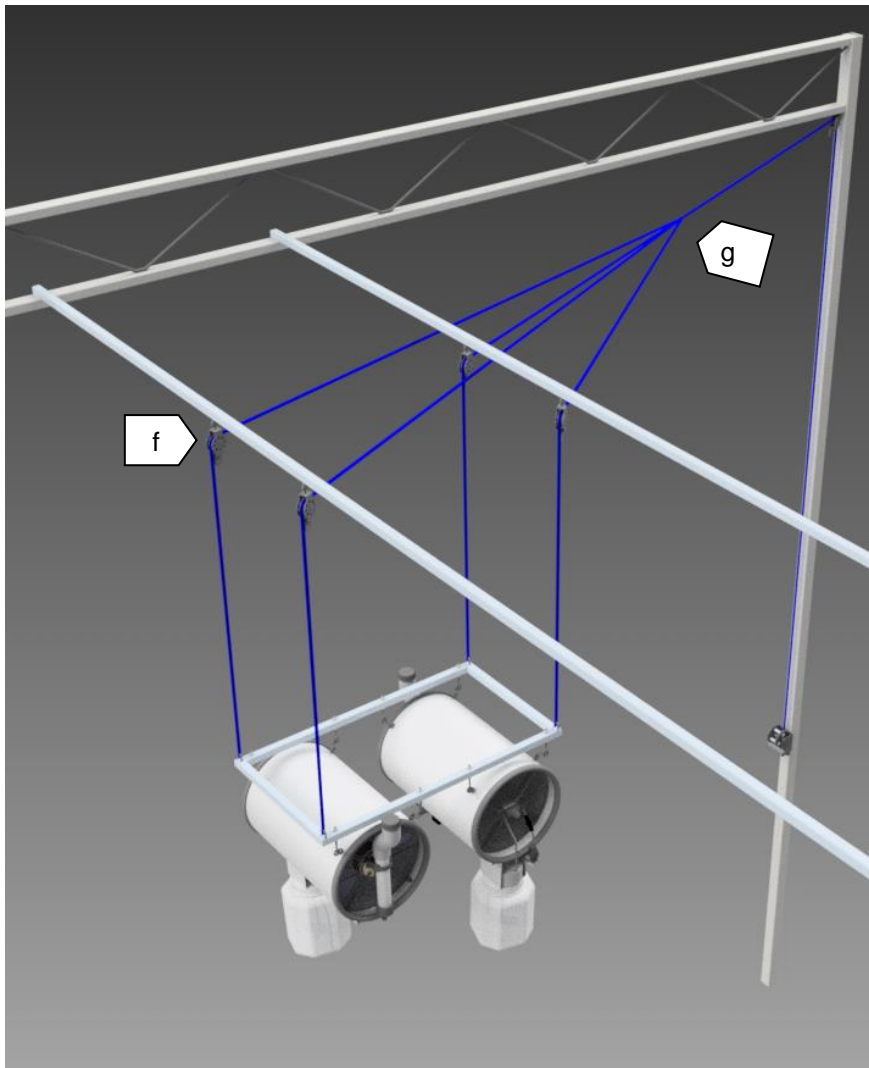

Picture 2 Example of the pulley suspension

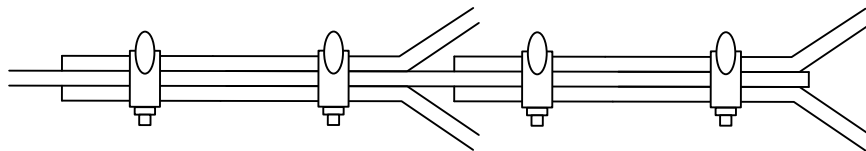
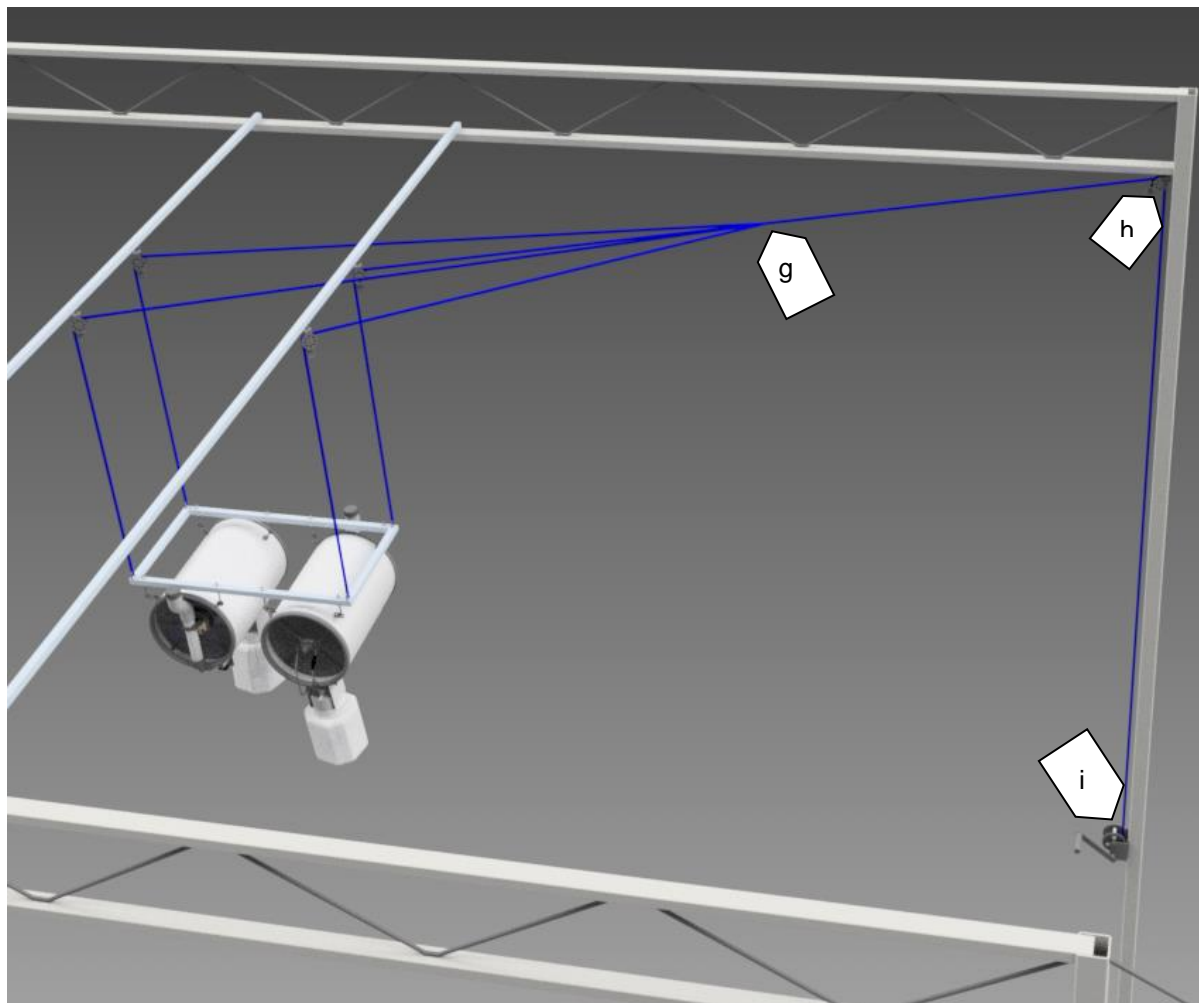

Figure 6 Example wire nodes with clamps

The pulleys(f) have to be mounted right above the mounting eyes (e) of the frame, one pulley per eye. There are no parts provided to mount the pulleys. The four wires from the frame are connected(g) after they are run through the pulleys. Figure 8 shows how this node could be connected. The wires are attached to one single wire that is attached to the winch.



Picture 3 Example of the pulley suspension

Behind the node, one wire runs through a pulley(h) that needs to be mounted to the nearest post. This pulley is right above the winch(i), that is also mounted to that same post. It is important that the distance from the node(g) to the pulleys is long enough so the node won't get tangled up with the pulleys when the Enbar is in its highest or lowest position. There are three extra pulleys supplied if there is a situation where more are needed.

For the single model there are 2 bolts (M8x100), included nuts, delivered to which the handle, with the upper ring, can be attached. The bolts must be mounted to the nearest post, one is for the upper position and the other one is for the lower position of the Enbar.

4.4 Pre-ventilation

- Pre-ventilation is required before commencing with the spraying operation;
 - This initiates the airflow in the greenhouse, thus enhancing the proper dispersion of the spraying agent throughout the crop spraying space.
- close all windows and doors to the exterior;
- switch on any auxiliary fans on in the enclosed space;
- allow the ventilator fan and the Enbar to pre-ventilate for at least ½ an hour.

4.5 Filling and start up

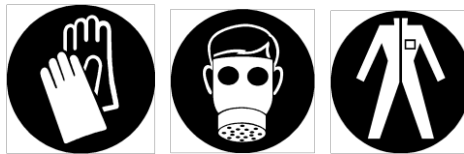

When preparing the crop spraying agent always wear gloves, protective clothing and a full face mask. Persons responsible for preparing crop spraying agents must be in the possession of a valid crop spraying license.

- Prepare the spraying fluid;
 - read the instructions provided by the supplier of the spraying agents;
- unscrew the fluid tank (6) from the underside of the Enbar;
- fill the fluid tank;
 - use a filter sieve to filter the fluid when filling;
- refit the fluid tank;
 - screw the fluid tank tightly;
- if there is no permanent water supply; fill the fluid tank with clean water;
 - ensure that the rinsing tank is full - almost all of the rinsing tank is required for rinsing;
- **Ensure that no persons are present in the enclosed crop spraying space**
- **Inform all personnel that spraying operations are about to begin**
- **Ensure that no persons can enter the space to be treated**
- follow all safety instructions in paragraph 3.3;
- when the Enbar starts up it will begin to pre-ventilate and then follow a preset program;
 - Atomizing/misting will commence after completion of the pre-ventilation cycle;
- when the misting period is completed the Enbar will automatically begin the rinsing and post-ventilation operation;
- the rinsing cycle comprises rinsing and ventilating with water, followed by the post-ventilation cycle;
- ensure that the crop space is well ventilated for several hours following the crop spraying operation.

4.6 Testing (U1 only)

The Enbar is equipped with a key-operate switch which enables the misting nozzle to be visually tested before use. Test the nozzle using clean water only, i.e. without the use of any chemicals!

- Insert the key into the key-operated switch (12);
- check that there is sufficient clean water in the fluid tank (6);
- ensure that no persons are standing in front of the nozzle (1);
- turn the key switch quarter of the way;
 - this will apply air and water pressure to the nozzle;
 - the nozzle should now begin misting, without all other functions such as ventilating;
- release the key switch;
 - the key switch returns automatically to its original position;
- remove the key from the key switch and keep it in a safe place.

4.7 Disconnecting



Always wear gloves, protective clothing and a full face mask when operating or working on the Enbar!
Disconnect the power supply and compressed air connection.



Only enter the crop space after the installation has completed the post ventilation cycle and the space has been well ventilated.

- Switch the Enbar off;



Remove the electrical power plug from the wall socket.

- carefully unscrew the fluid tank (6) from the underside of the Enbar;
 - There will be +/-0,5liter of wastewater in the fluid tank, this must be drained of.
- rinse out the fluid tank;
 - use mains water at a temperature of 40°C;
 - the rinsing program has ensured that the fluid tank, the suction pipe (4), flow limiter (2), filter (3) and the fluid lines and the nozzle (1) are rinsed with clean water;
- leave a small quantity of clean water in the fluid tank;
 - this will prevent the fluid lines etc. from drying out;
- screw the fluid tank into position again;
- if the Enbar has no permanent water connection: fill the rinsing tank (8) described in paragraph 2.2 with clean water.

4.8 Starting after a power interruption

The Enbar will not automatically resume its preset operating program after a power interruption caused by a power failure or after pressing the emergency stop button.

- determine the cause of the power failure.
- if possible, resolve the cause of the power failure.
- check that there are no persons present in the space where spraying is to be performed.
- press the start button on the central control unit;
 - the Enbar will now perform a pre-ventilation cycle for 5 minutes and then resume its preset program.

5 MAINTENANCE

This section describes how maintenance on the Enbar is performed. Only those maintenance tasks described in this manual may be performed independently. Any other maintenance tasks must be carried out by a certified maintenance technician/company.



Always wear gloves, protective clothing and a full face mask when operating or working on the Enbar!

Disconnect the power supply and compressed air connection.

5.1 Cleaning after use

- The rinsing program has ensured that the fluid tank, the suction pipe (4), flow limiter (3), filter (2) and the fluid lines and the nozzle (1) are rinsed with clean water;
- carefully unscrew the fluid tank (6) from the underside of the unit;
 - There will be +/-0,5liter of wastewater in the fluid tank, this must be drained of.
- rinse out the fluid tank;
 - drop fluid as chemical trash;
 - use mains water at a temperature of 40°C;
- leave a small quantity of clean water in the fluid tank;
 - this prevents fluid lines etc. from drying out;
- refit the fluid tank to the unit;
- fill the fluid tank (8) with clean water;
- clean the unit;
 - use a non-corrosive (household) cleaning agent;
- check the Enbar for any leakages and for wear of hoses and cables;
- check the covers and/or the grille guards of the Enbar;
- check the couplings, nuts and bolts.

5.2 Yearly maintenance

5.2.1 Safety regulations

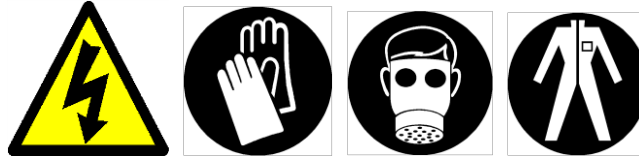

Always wear gloves, protective clothing and a full face mask when operating or working on the Enbar!

Always disconnect the power supply!
Disconnect the compressed air line!
Disconnect the water line!

Never allow the ventilator fan to operate

5.2.2 Unit

- Disconnect the power supply;
- disconnect the compressed air coupling;
- disconnect the water coupling;

- clean the fan blades;
 - unscrew the protective guard(s) of the ventilator fan(s);
 - clean the fan blades using water and soap;
 - refit the grille guard;

- clean out the fluid tank (6);
 - remove the fluid tank;
 - rinse the tank with plenty of clean water;
 - if necessary, clean the tank with soap and water;

- check the mixing paddle (5);
 - switch on the Enbar via the central control unit;
 - insert the plug into the electrical wall socket;
 - the mixing paddle should now rotate;
 - if the mixing paddle fails to operate, contact the supplier;
 - remove the electrical power plug from the wall socket;
 - switch off the Enbar via the central control unit;
 - refit the fluid tank;

- clean the filter in the suction line (3);
 - dismantle the suction filter;
 - use the exploded view in the attachment (page 39) as a guide;
 - clean the filter;
 - use mains water at a temperature of 40°C;
 - mount the filter and any sealing rings in the fluid line;

- clean the nozzle (1);
 - dismantle the nozzle;
 - use the exploded view in the attachment (page 38) as a guide;
 - check the nozzle for wear;
 - replace the nozzle with a repair set or place refit the original nozzle;

- check the capacity of the nozzle (1) and the flow limiter (2);
 - fill the fluid tank (6) met 200 cc (= 200 ml) of clean water;
 - clean the installation;
 - follow the instructions given in paragraph 4.5;
 - check the misting period with the help of a wrist watch or stop watch;
 - all water must be used up within 6 minutes;
 - if this occurs too quickly, the nozzle needs to be replaced. If this occurs too slowly, the nozzle and the flow limiter need to be cleaned or replaced;

- check the rinsing operation of the unit;
 - fill the rinsing tank with clean water (only if there is no permanent water connection available);
 - almost all of the content of the rinsing tank is required for rinsing;
 - allow the installation to mist for a short while using clean water;
 - the rinsing cycle should now begin;
 - some of the contents of the rinsing tank are immediately atomized. The remainder is retained by the flow limiter and is pumped into the fluid tank;
 - almost all of the contents of the rinsing tank are used;
 - After rinsing there will be +/-0,5liter wastewater in the fluid tank, this must be drained of.

- clean the installation;
 - clean the unit;
 - use a non-corrosive (household) cleaning agent;
 - check the Enbar for any leakages and for wear of hoses and cables;
 - check the covers and/or the grille guards of the Enbar;
 - check connections and all nuts and bolts;
 - leave a small quantity of clean water in the fluid tank;
 - this prevents fluid lines etc. from drying out.

6 TROUBLESHOOTING

The control unit under the Enbar includes a circuit diagram of the unit. This diagram is intended for use by a professional and competent electrical technician in the event of machine malfunctions. Simple malfunctions can be solved by following the instructions in the table below.

problem	cause	solution
The ventilator fan of the Enbar fails to rotate	Defective fuse in (central) control unit under the Enbar	Remove the electrical power plug from the wall socket and check or replace the fuses as instructed in the annex. Contact your supplier if the fuse blows again. Fuse type; 4A glass fuse
	Malfunction in the control current device	Contact your supplier
The unit fails to produce mist (no air and no fluid)	Compressor defect	Check that the air connection is properly connected and that there is a sufficient supply of compressed air.
	Air connection is closed off	Check that the air connection is properly connected and that there is a sufficient supply of compressed air.
	Magnetic valve is defect	Contact your supplier
	By U1 version: Relay defect or both type 24 Volt supply absent	Contact your supplier
Unit blows air but does not mist	No fluid intake - the suction pipe is blocked or broken	Remove the hose from the suction pipe and rinse or replace it.
	Flow limiter is blocked	Dismantle this part together with all hoses and replace it.
	Nozzle is blocked	Carefully dismantle and remove the nozzle and clean all parts do not use a metal file or abrasive paper etc.
	Nozzle sealing leaks	Dismantle the nozzle and replace the sealing.
	Suction filter is blocked	Remove the filter and rinse it thoroughly.
	Sealing of suction filter leaks	Remove the filter and replace the sealing.

Table 12 Possible malfunctions and solutions

If the Enbar is sent out for repairs the fluid tanks must first be emptied and cleaned.



7 CE DECLARATION OF CONFORMITY

EC DECLARATION OF CONFORMITY

(in accordance with Annex II A of the 2006/42/EC Directive on Machinery)

We, Van der Ende Pompen
Aartsdijkweg 23
2676 LE Maasdijk
Netherland

affirm that the machine designated as

Enbar LVM
U1, U2, 1-U3 en 22-U3

manufactured by us fulfils the requirements of the following Directives

2006/42/EC Directive on Machinery
Low Voltage Directive (LVD) 2006/95/EC
and the Directive of Electromagnetic Compatibility (EMC) 2004/108/EC

and that the construction of the equipment and machinery is in accordance with the following harmonized standards:

not applicable

Netherlands
Maasdijk
25 October 2019

L. van der Ende



8 UKCA DECLARATION OF CONFORMITY

UKCA DECLARATION OF CONFORMITY

We, Van der Ende Pompen
Aartsdijkweg 23
2676 LE Maasdijk
Netherland

affirm that the machine designated as

Enbar LVM
U1, U2, 1-U3 en 22-U3

manufactured by us fulfils the requirements of the following directives and their admendments;

Supply of Machinery (Safety) Regulations	2008:1597
Electrical Equipment (Safety) Regulations	2016:1101
Electro Magnetic Compatibility Regulations	2016:1091

and that the construction of the equipment and machinery is in accordance with the following harmonized standards:

not applicable

Netherlands
Maasdijk
13 December 2022

L. van der Ende



ANNEXES

- Exploded view of Nozzle
- Exploded view of fluid filter
- Electrical wiring diagram U1
- Fuse replacement in U1 type
- Time cycle diagram

Construction of the nozzle

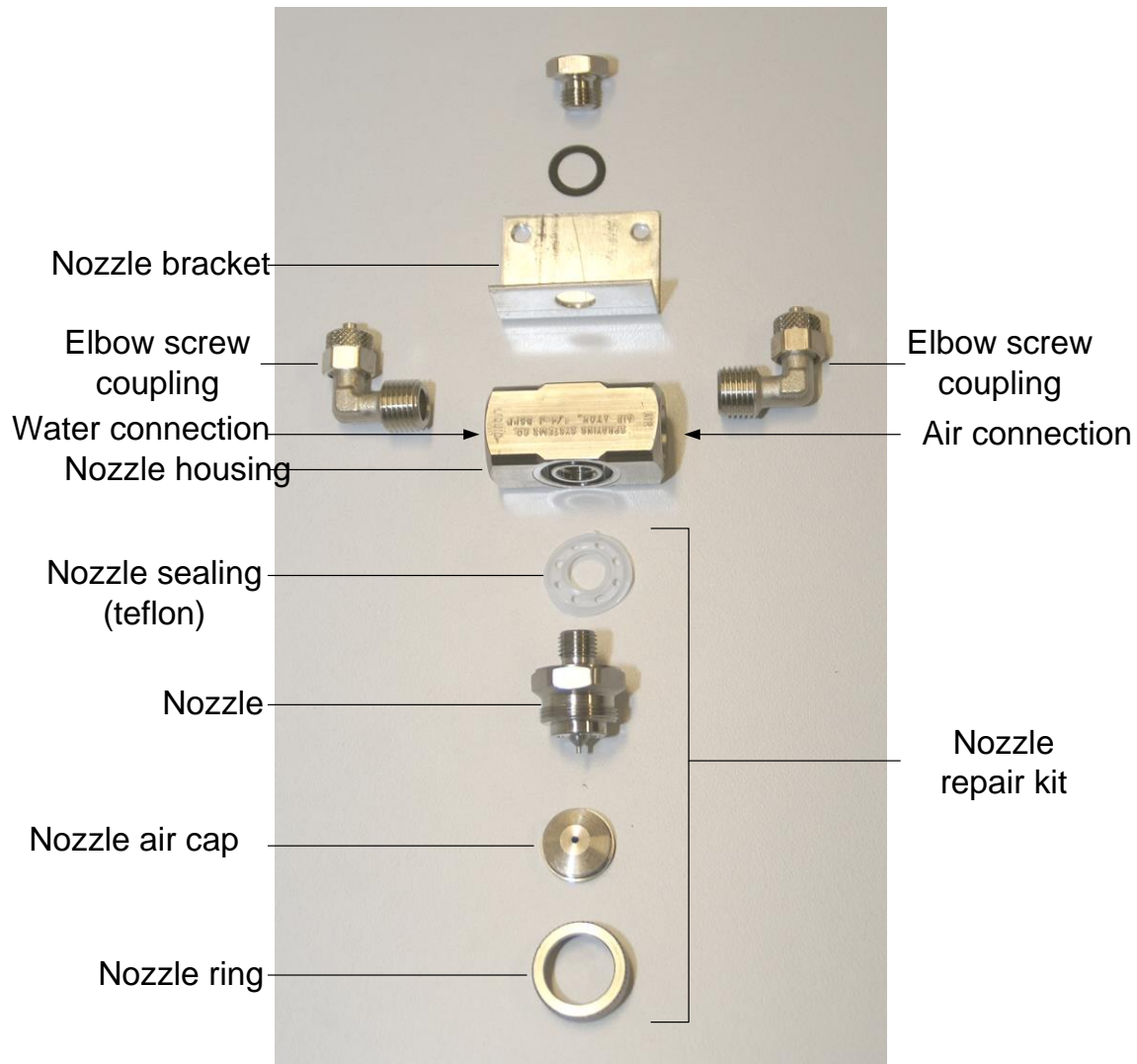

The nozzle bracket, nozzle housing, nozzle sealing and the elbow screw couplings can be obtained separately from the manufacturer. The nozzle sealing, nozzle, nozzle air cap and nozzle ring can be obtained as a repair kit. With the exception of the nozzle sealing, these components cannot be obtained separately.

The fluid and air connections can be recognized by the designations “liquid” (fluid) and “air” engraved into the nozzle housing.

The top bolt (for attaching the nozzle bracket to the nozzle housing) is sealed with green Loctite. This cannot be dismantled after removal.

Construction of the fluid filter

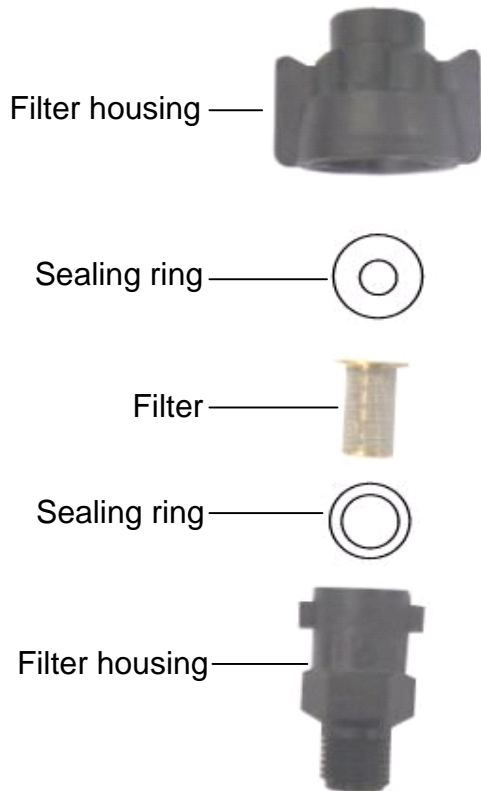

Electrical wiring diagram U1

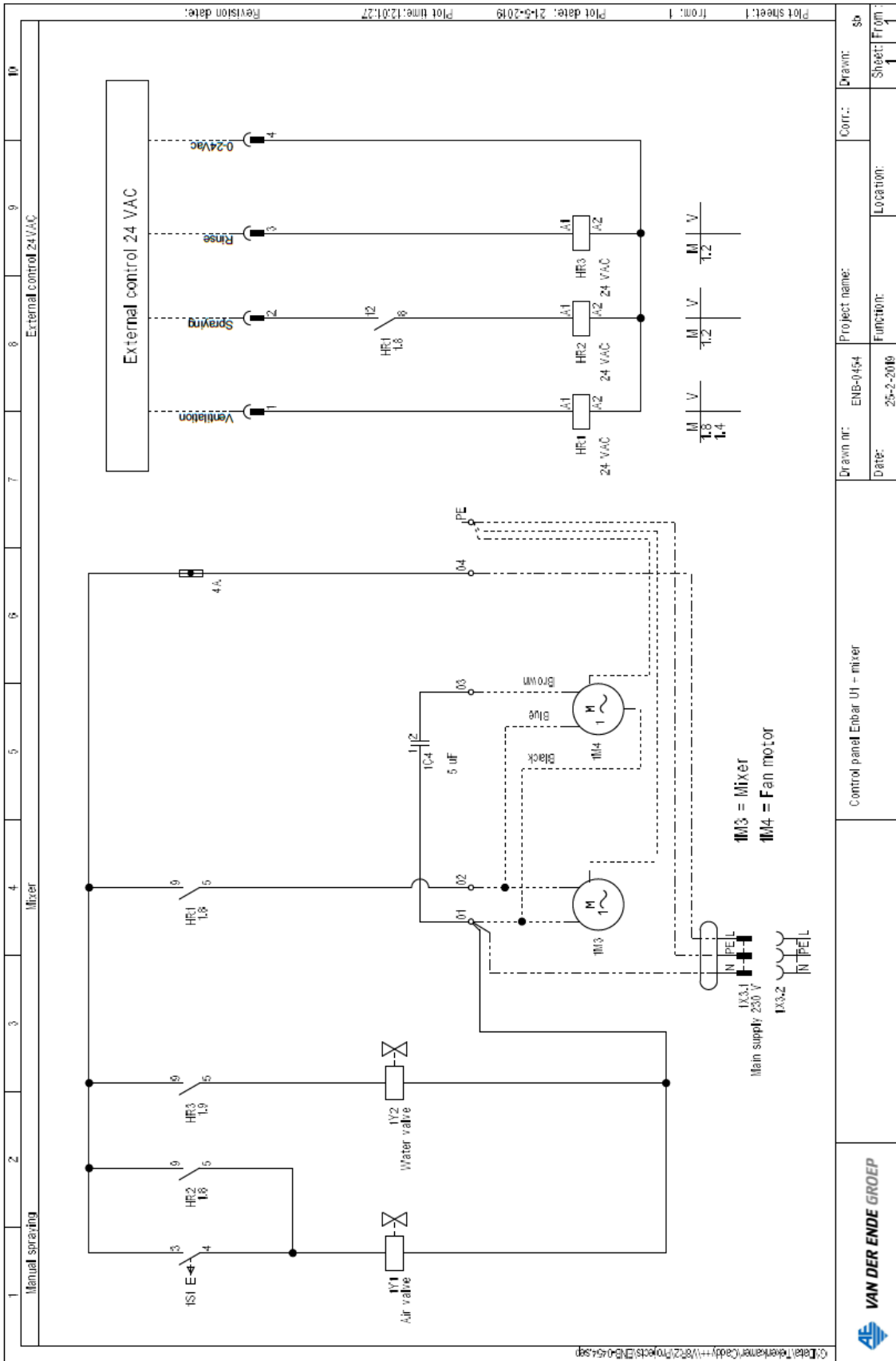

Replacement of fuse in U1 type

When a blown fuse in the control unit is suspected, this must be checked and, if necessary, be replaced by a new fuse. Follow the instructions given below.

Before working on the Enbar, always disconnect the electrical power supply!

Ensure that work can be carried out on the Enbar safely. If in doubt, always consult an expert or contact the manufacturer.

The image below is of the U1. The control unit of the U2 is slightly different. However, this has no effect on the procedure described below.

Unscrew the control unit;
unscrew the 4 screws in each corner;
remove the cover;
pull the tab of the fuse holder backwards;
the U2 and U1 both have 1 glass fuse holder, as shown in the image below:
check the glass fuse or replace it;
the fuse is a 4A fuse cartridge;
close the glass fuse holders by pressing;
screw the cover on again tightly;

Fuse holder

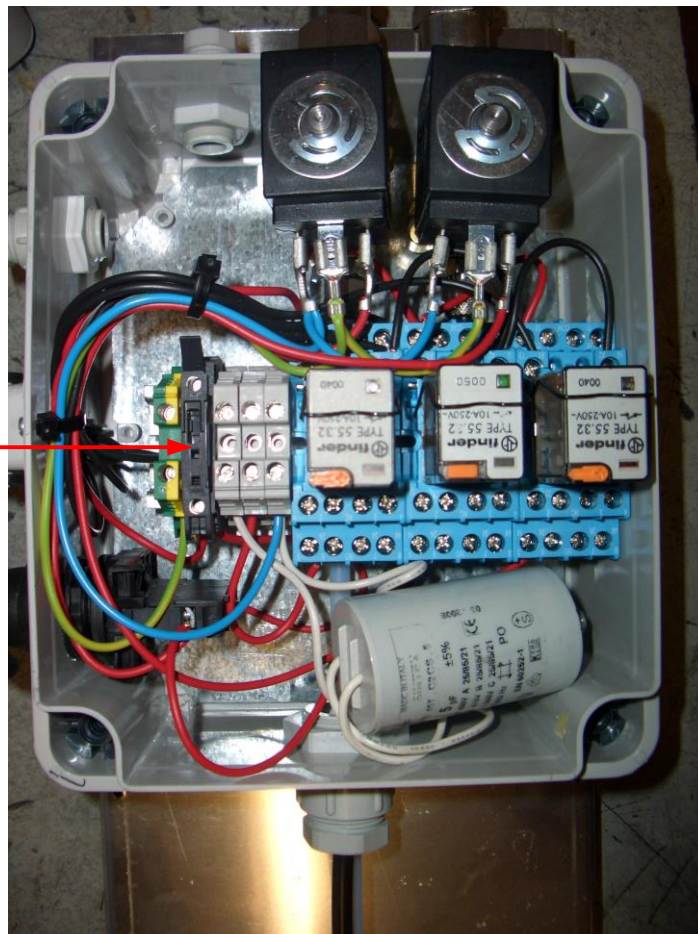

Time cycle diagram

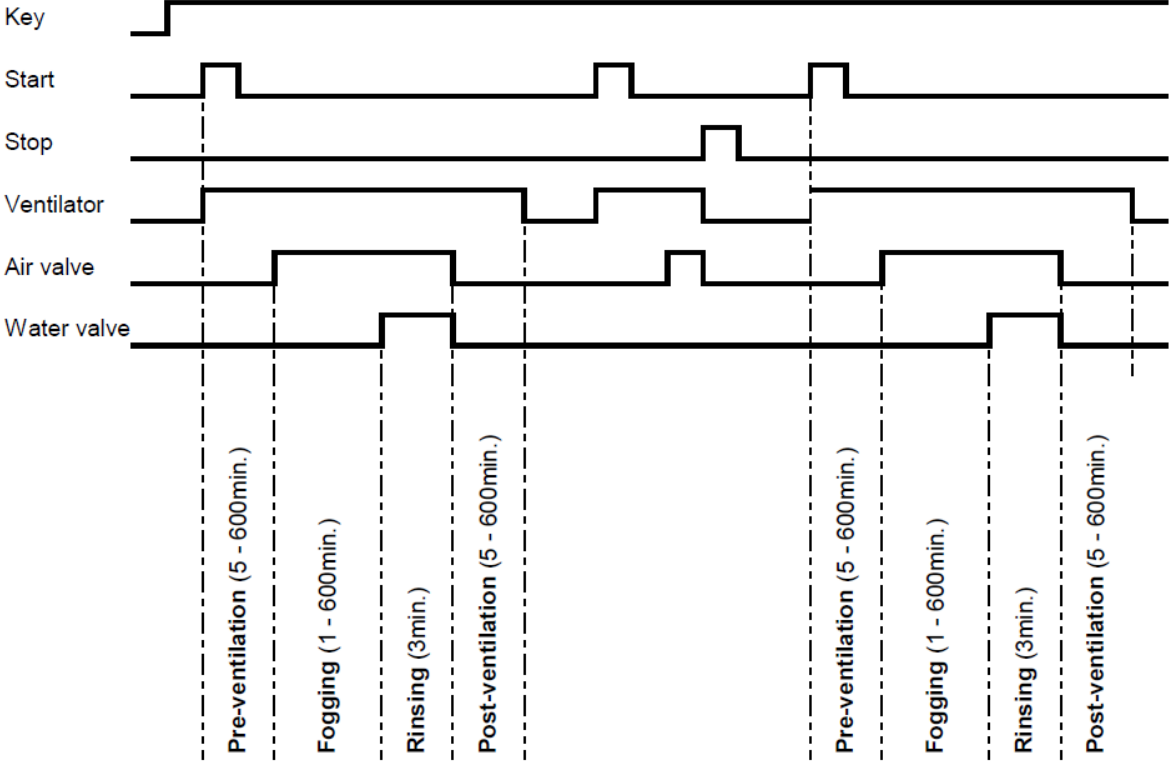

The information in this manual should be considered true and correct to the best of our knowledge of which no rights may be derived. Misprints and changes in technique and procedures reserved. Subsequent damage is not refunded.





Aartsdijkweg 23, 2676 LE Maasdijk, The Netherlands
+31 174 51 50 50 · info@vanderendegroup.com · www.vanderendegroup.com