

# ENMIX BASIC

## low-speed mixer



### Agitator mixers

#### **Description**

This low-speed agitator mixer is the ideal solution for mixing liquids and keeping them in motion in fertiliser tanks or tanks for other mixed liquids. It can also be used for mixing solid fertilisers, for example from big bags. The Enmix Basic consists of a frame, a motor with reduction gearbox, and a shaft with mixer blade. In modern greenhouse horticulture, the ever-increasing size of mixing tanks can create problems when solid fertilisers need to be properly dissolved in the water. The Enmix Basic mixer is the optimum solution for this.

The mixer and mounting frame are made entirely of stainless steel and are delivered as a flatpack for self-assembly, according to the dimensions of the mixing tank. The mixer blade has a turn diameter of 75 cm (or 100 cm in the 50 Hz variant), rotating slowly and ensuring that all the contents of the tank, up to a maximum volume of 10 m<sup>3</sup>, are kept sufficiently in motion. The Enmix Basic is delivered in three packages: the electric motor with reduction gearbox, the frame and the mixing attachment. For tanks with a depth > 100 cm, there is also an additional package: a shaft guide bearing, which is easy to fasten to the frame and gives extra support for the mixing attachment.

The frame and mixer are available in two types, long and short, and they can be adjusted to fit the dimensions of the tank, up to a maximum width of 246 cm and depth of 150 cm. The Enmix Basic can be assembled on-site to meet your precise specifications. So there's always a perfect Enmix Basic mixer for every application, and you have the optimum solution for mixing fertilisers. The Enmix Basic is supplied in 304 stainless steel.

If you plan to use the Enmix Basic in a round tank, we advise you to fit two vertical strips inside the tank to prevent a vortex or swirling motion of the entire contents. These strips serve as anti-vortex baffles around the shaft and ensure correct mixing within the tank.

The Enmix Basic: a standard, compact agitator mixer, delivered as a flatpack for self-assembly.



## Advantages

- o low energy consumption
- o no foaming
- o compact, self-assembly flatpack (export)
- o several basic variants
  - for different tank spans
  - for different tank depths
- o standard product for different tank dimensions

## Technical specifications

- o motor with reduction gearbox:
  - power: 0.37 kW
  - transmission ratio: 15:1
  - ingress protection rating: IP55
- o mixer:
  - speed: 94 rpm (50 Hz variant)
  - 112 rpm (60 Hz variant)
- o material of frame, shaft and mixer blade: 304 stainless steel

Frequency	Voltage	Current	Speed	Phases	Weight	Certification
50 Hz *	230 V	2,00 A	1370 rpm	1 phase	6,2 kg	CE
50 Hz *	400 V	1,15 A	1410 rpm	3 phase	5,4 kg	CE
60 Hz	440 - 480 V	1,15 A	1680 rpm	3 phase	5,4 kg	CE
60 Hz	480 V	0,91 A	1715 rpm	3 phase	9,5 kg	cUrus
60 Hz	575 - 600 V	0,70 A	1680 rpm	3 phase	8,0 kg	cUrus

\* Only available with 100 cm mixer blade. Other frequencies and voltages available on request.

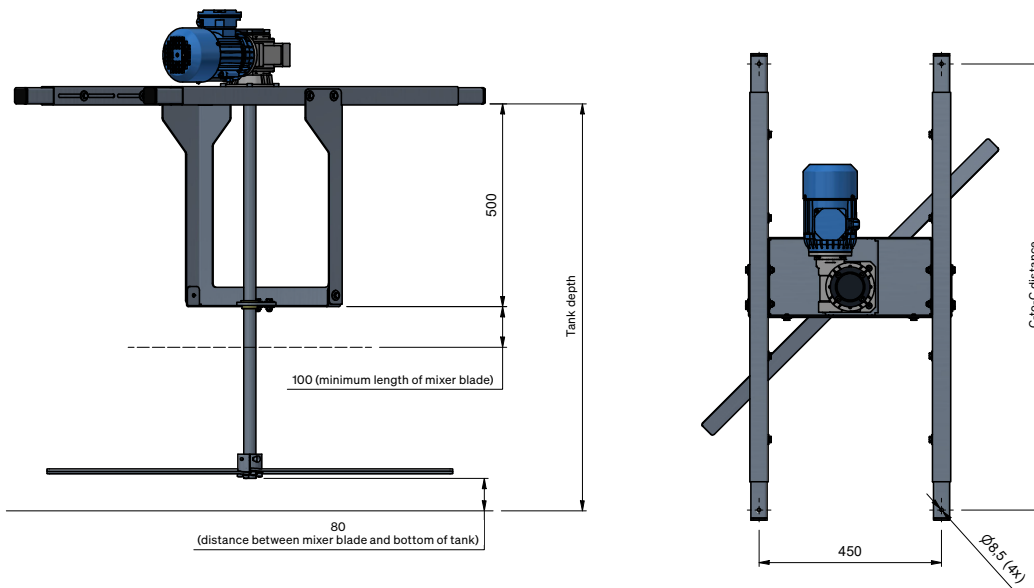

	Minimum C-to-C distance	Maximum C-to-C distance
Frame: short	1100	1780
Frame: long	1780	2460
	Minimum tank depth	Maximum tank depth
Shaft: short	180	1000
Shaft: long (incl. shaft guide bearing)	680	1500